



Precision Linear Pack

THK General Catalog

A Product Descriptions

Features	A6-2
Features of the Precision Linear Pack ..	A6-2
• Structure and Features	A6-2
Rated Load and Nominal Life.....	A6-3
Accuracy Standards	A6-5
Radial Clearance	A6-5
Dimensional Drawing, Dimensional Table	
Model ER.....	A6-6
Model No.	
• Model Number Coding	A6-8
Precautions on Use	A6-9

B Support Book (Separate)

Features	B6-2
Features of the Precision Linear Pack ..	B6-2
• Structure and Features	B6-2
Rated Load and Nominal Life	B6-3
Model No.	
• Model Number Coding	B6-6
Precautions on Use	B6-7

Features of the Precision Linear Pack

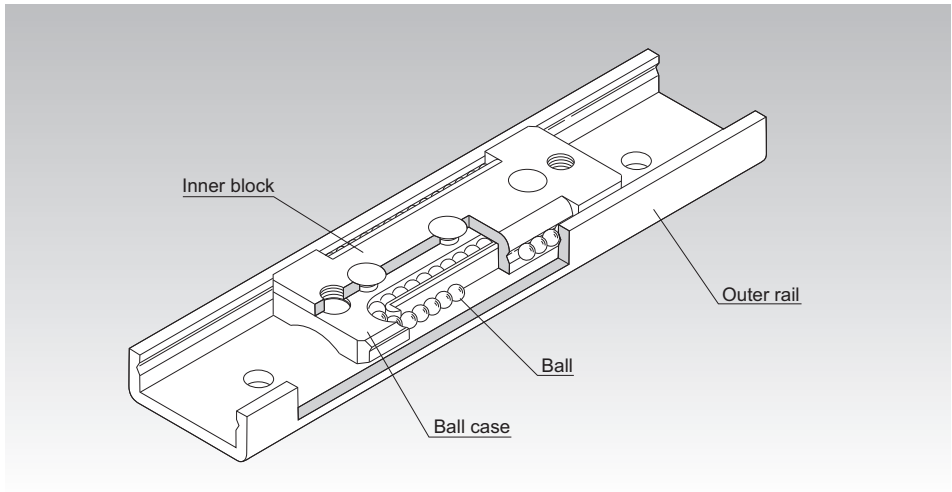

Fig.1 Structure of Precision Linear Pack Model ER

Structure and Features

Model ER is a slide unit using a stainless steel plate that is precision formed, heat-treated and then ground. It has a structure where balls roll between the V-shaped grooves machined on the outer rail and the inner block to allow the system to slide. It is an ultra-thin, lightweight unit in which the balls circulate in a ball case incorporated in the inner block to perform infinite straight motion.

This model is used in extensive applications such as magnetic disc devices, electronic equipment, semiconductor manufacturing equipment, medical equipment, measuring equipment, plotting machines and photocopiers.

[Reduced Design and Assembly Costs]

It provides a highly accurate linear guide system with lower design cost and fewer assembly man-hours than the conventional miniature ball bearings used in precision machines and other equipment.

[Maintains Long-term Stability]

It is a ball-circulating type slide unit with an extremely small friction coefficient. This slide unit maintains stable performance over a long period of time.

[Lightweight, Compact Design and High-speed Response]

The outer rail and the inner block are composed of very thin stainless steel plates. Since the linear pack is light, it has a small inertial moment and demonstrates superb high-speed response.

Rated Load and Nominal Life

[Rated Loads in All Directions]

The basic load rating in the specification table indicates the rated load in the radial direction as shown in Fig.2. The rated loads in the reverse radial and lateral directions are obtained from Table1 below.

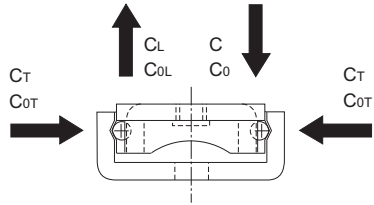

Fig.2 Rated Loads in All Directions

Table1 Rated Loads in All Directions

	Basic dynamic load rating	Basic static load rating
Radial direction	C (indicated in the specification table)	C ₀ (indicated in the specification table)
Reverse radial direction	C _L =C	C _{0L} =C ₀
Lateral directions	C _T =1.47C	C _{0T} =1.73C ₀

[Static Safety Factor f_s]

Model ER may receive an unexpected external force while it is stationary or operative due to the generation of an inertia caused by vibrations and impact or start and stop. It is necessary to consider a static safety factor against such a working load.

$$f_s = \frac{f_c \cdot C_0}{P_c}$$

- f_s : Static safety factor (see Table2)
- f_c : Contact factor (see Table3 on **A6-4**)
- C₀ : Basic static load rating (N)
- P_c : Calculated load (N)

● Reference Value of Static Safety Factor

The static safety factors indicated in Table2 are the lower limits of reference values in the respective conditions.

Table2 Reference Value of Static Safety Factors (f_s)

Machine using the LM system	Condition	Lower limit of f _s
General industrial machinery	Without vibration or impact	1 to 1.3
	With vibration or impact	2 to 7

[Nominal Life]

The nominal life of model ER is obtained using the following equation.

$$L = \left(\frac{f_c}{f_w} \cdot \frac{C}{P_c} \right)^3 \times 50$$

- L : Nominal life (km)
(The total number of revolutions that 90% of a group of identical ER units independently operating under the same conditions can achieve without showing flaking)
- C : Basic dynamic load rating (N)
- P_c : Calculated load (N)
- f_c : Contact factor (see Table3)
- f_w : Load factor (see Table4 on **A6-5**)

[Calculating the Service Life Time]

When the nominal life (L) has been obtained, if the stroke length and the number of reciprocations per minute are constant, the service life time is obtained using the following equation.

$$L_h = \frac{L \times 10^6}{2 \times l_s \times n_1 \times 60}$$

- L_h : Service life time (h)
- l_s : Stroke length (mm)
- n₁ : Number of reciprocations per minute (min⁻¹)

● f_c: Contact Factor

When multiple inner blocks are used in close contact with each other, their linear motion is affected by a moment load and mounting accuracy, making it difficult to achieve uniform load distribution. In such applications, multiply the basic load rating (C) and (C₀) by the corresponding contact factor in Table3.

Table3 Contact Factor (f_c)

Number of inner blocks in close contact with each other	Contact factor f _c
2	0.81
3	0.72
Normal use 1	1

● **f_w : Load Factor**

In general, reciprocating machines tend to involve vibrations or impact during operation. It is extremely difficult to accurately determine vibrations generated during high-speed operation and impact during frequent start and stop. Therefore, when the actual load applied on model ER cannot be obtained, or when speed and vibrations have a significant influence, divide the basic dynamic load rating (C) by the corresponding load factor in Table4 of empirically obtained data.

Table4 Load Factor (f_w)

Vibrations/impact	Speed (V)	f_w
Faint	Very low $V \leq 0.25\text{m/s}$	1 to 1.2
Weak	Slow $0.25 < V \leq 1\text{m/s}$	1.2 to 1.5

Accuracy Standards

The running straightness of model ER is indicated in Table5. (See Fig.3.)

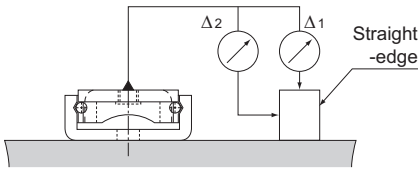

Fig.3 Method for Measuring Running Straightness

Table5 Running Straightness Unit: mm

Stroke length		Running straightness of inner block in vertical directions $\Delta 1$	Running straightness of inner block in horizontal directions $\Delta 2$
Above	Or less		
—	20	0.002	0.004
20	40	0.003	0.006
40	60	0.004	0.008
60	80	0.005	0.010
80	100	0.006	0.012
100	120	0.008	0.016

Radial Clearance

The radial clearance of model ER means the value for the motion of the central part of the inner block when the inner block is slightly moved with a vertically constant force in the middle of the outer rail in the longitudinal direction. The negative values in table 6 indicate that the respective models are provided with a preload when assembled and have no clearance between their inner blocks and the outer rails.

Table6 Radial Clearance Unit: μm

Model No.	Radial clearance	
	Normal	C1
ER 513	± 2	-2 to 0
ER 616	± 2	-3 to 0
ER 920	± 2	-4 to 0
ER 1025	± 3	-6 to 0

Note) When desiring normal clearance, add no symbol; when desiring C1 clearance, indicate "C1" in the model number. (see "Model number coding" on **A6-8**)

Model ER

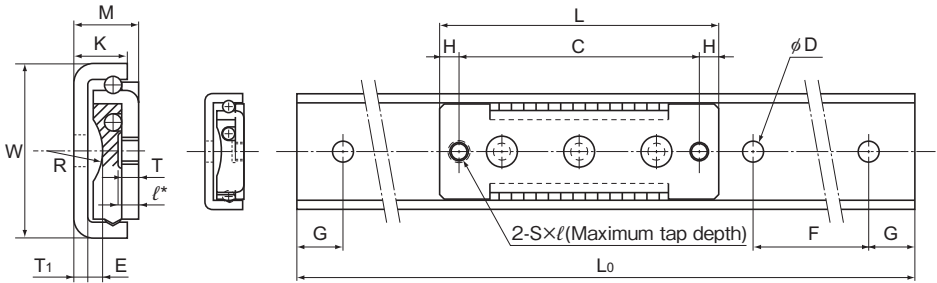

Magnified view

Model No.	Inner block dimensions									
	Width W	Height M ±0.05	Length L	C	H	E	R	S	Maximum tap depth ℓ*	T
ER 513	13	4.5	22	7	7.5	1.1	4.2	M2	1.3	0.9
ER 616	15.6	6	36	29	3.5	1.7	9.2	M3	1.8	1.1
ER 920	20	8.5	46	40	3	2.3	7.3	M3	2.5	1.9
ER 1025	25	10	56	48	4	2.9	9.3	M4	2.8	2.2

Model number coding

2 ER616 C1 +95L

Model number

Outer rail length (in mm)

Radial clearance symbol (*1)

Number of inner blocks used on the same rail
(no symbol for a single slider)

(*1) See **A6-5**.

Unit: mm

Outer rail dimensions							Basic load rating		Mass	
K	T ₁	D	L ₀	F	G	C N	C ₀ N	Inner block g	Outer rail g/m	
4	1.1	2.4	40, 60, 80	20	10	54.9	72.5	2.4	166	
5.5	1.4	2.9	45, 70, 95	25	10	71.6	125	5.6	268	
7.5	1.9	3.5	50, 80, 110	30	10	144	201	14.4	474	
9	2.2	4.5	60, 100, 140	40	10	215	315	27	677	

Note1) To fix the outer rail of models ER513 and ER616, use cross-recessed pan head screws for precision equipment (No. 0 screw). To fix the outer rail of models ER920 and ER1025, cross-recessed pan head screws.

Note2) * Set the screw length so that it does not exceed the "Maximum tap depth" ℓ .

Model No.	Type	Nominal name of screw × pitch
ER 513	No. 0 pan-head screw (class 1)	M2×0.4
ER 616		M2.6×0.45
ER 920	Cross-recessed pan head screw	M3×0.5
ER 1025		M4×0.7

- *Japan Camera Industry Association Standard JCIS 10-70
- Cross-recessed screw for precision equipment (No. 0 screw)
- *Cross-recessed pan head screw JIS B 1111

Model Number Coding

Model number configurations differ depending on the model features. Refer to the corresponding sample model number configuration.

[Precision Linear Pack]

- Model ER

2 ER616 C1 +95L

|
|
|
|

Model No.
Outer rail length (in mm)

Radial clearance symbol (*1)

Number of inner blocks used on the same rail

(no symbol for one nut)

(*1) See **A6-5**.

[Handling]

- (1) Do not disassemble the parts. This will result in loss of functionality.
- (2) Take care not to drop or strike the Precision Linear Pack, which could result in injury or damage. A forceful impact could cause impair its function, even if there is no visible damage.
- (3) Removing the inner block of the Precision Linear Pack from the outer rail or letting it overshoot will cause balls to fall off.
- (4) When handling the product, wear protective gloves, safety shoes, etc., as necessary to ensure safety.

[Precautions on Use]

- (1) Prevent foreign material, such as cutting chips or coolant, from entering the product. Failure to do so may cause damage.
- (2) In the event that cutting chips or other foreign matter adheres to the unit, clean it off and reapply lubricant.
- (3) Do not use the product at temperature of 80°C or higher.
- (4) Using the product with some of the rolling elements missing may cause damage at an early stage.
- (5) If any of the rolling elements falls, contact THK instead of using the product.
- (6) Insufficient rigidity or accuracy of mounting members causes the bearing load to concentrate on one point and the bearing performance will drop significantly. Accordingly, give sufficient consideration to the rigidity/accuracy of the housing and base and strength of the fixing bolts.
- (7) Micro-strokes tend to obstruct oil film to form on the raceway in contact with the rolling element, and may lead to fretting corrosion. Take consideration using grease offering excellent fretting prevention. THK also recommends periodically executing a full stroke with the unit to ensure that the raceway and balls are coated with lubricant.

[Lubrication]

- (1) Thoroughly remove anti-rust oil with a cleaning detergent and apply lubricant before using the product. As the most suitable grease, we recommend THK AFC Grease, which maintains lubricity over a long period of time. For lubrication in a clean room, low dust generation THK AFE-CA Grease and THK AFF Grease are recommended.
- (2) Do not mix different lubricants. Mixing greases using the same type of thickening agent may still cause adverse interaction between the two greases if they use different additives, etc.
- (3) When using the product in locations exposed to constant vibrations or in special environments such as clean rooms, vacuum and low/high temperature, use the grease appropriate for the specification/environment.
- (4) When lubricating the product, apply grease directly on the raceway and stroke the product several times to let the grease spread inside.
- (5) The consistency of grease changes according to the temperature. Take note that the slide resistance of the Precision Linear Pack also changes as the consistency of grease changes.
- (6) After lubrication, the slide resistance of the Precision Linear Pack may increase due to the agitation resistance of grease. Be sure to perform a break-in to let the grease spread fully, before operating the machine.
- (7) Excess grease may scatter immediately after lubrication, so wipe off scattered grease as necessary.

- (8) The properties of grease deteriorate and its lubrication performance drops over time, so grease must be checked and added properly according to the use frequency of the machine.
- (9) The greasing interval varies depending on the use condition and service environment. Set the final lubrication interval/amount based on the actual machine.

[Installation]

The mounting surface of the model ER Precision Linear Pack must be finished with the highest possible precision.

Use commercially available no. 0 pan head machine screws designed for precision equipment to anchor the outer rail of models ER513 and ER616 (with ordinary screws, the head of the screw could come into contact with inner block). Use commercially available Phillips pan head machine screws to anchor the outer rail of models ER920 and ER1025. (See Table1.)

Table1 Outer rail mounting screws

Model No.	Type	Nominal name of screw × pitch
ER513	No. 0 pan-head screw (class 1)	M2×0.4
ER616		M2.6×0.45
ER920	Cross-recessed pan head screw	M3×0.5
ER1025		M4×0.7

* Japan Camera Industry Association Standard JClS 10-70
Cross-recessed screw for precision equipment (No. 0 screw)

* Cross-recessed pan head screw JIS B 1111

[Storage]

When storing the Precision Linear Pack, enclose it in a package designated by THK and store it in a room in a horizontal orientation while avoiding high temperature, low temperature and high humidity.

[Disposal]

Dispose of the product properly as industrial waste.