

Model LTR

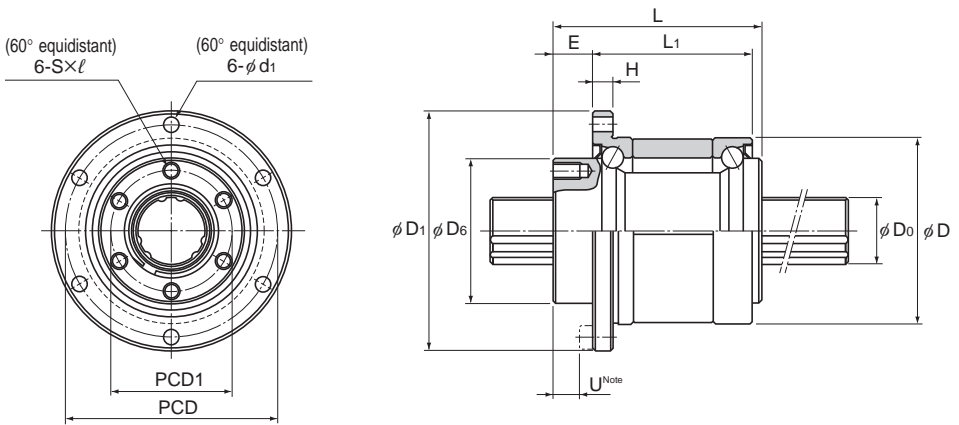

Model No.	Spline nut dimensions										
	Outer diameter		Length L	Flange diameter D ₁	D ₆ h7	H	L ₁	E	PCD	PCD1	S × l
	D	Tolerance									
LTR 16	52	0 -0.007	50	68	39.5	5	37	10	60	32	M5 × 8
LTR 20	56		63	72	43.5	6	48	12	64	36	M5 × 8
LTR 25	62		71	78	53	6	55	13	70	45	M6 × 8
LTR 32	80		80	105	65.5	9	60	17	91	55	M6 × 10
LTR 40	100	0 -0.008	100	130	79.5	11	74	23	113	68	M6 × 10
LTR 50	120		125	156	99.5	12	97	25	136	85	M10 × 15
LTR 60	134		140	170	115	12	112	25	150	100	M10 × 15

Model number coding

2 LTR50 K UU ZZ CM +1000L H K

Model No.	Flange orientation symbol ^(*1)	Symbol for clearance in the rotational direction ^(*4)	Accuracy symbol ^(*5)	Symbol for standard hollow spline shaft ^(*6)
Number of spline nuts on one shaft (no symbol for one nut)	Spline nut contamination protection accessory symbol ^(*2)	Support bearings contamination protection accessory symbol ^(*3)	Overall spline shaft length ^(*7) (in mm)	

(*2) See **A3-113**. (*3) See **A3-113**. (*4) See **A3-29**. (*5) See **A3-33**. (*6) See **A3-106**. (*7) See **A3-109**.

(*1) No Symbol: standard K: flange inverted

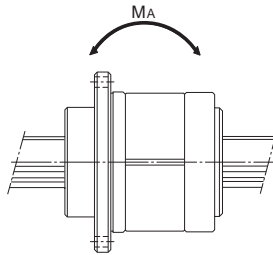

Unit: mm

			Spline shaft diameter		Basic torque rating		Basic load rating		Static permissible moment	Support bearing basic load rating		Mass	
	d_1	U ^{Note}	D_0 h7	Rows of balls	C_T N·m	C_{0T} N·m	C kN	C_0 kN	M_A^{**} N·m	C kN	C_0 kN	Spline Nut kg	Spline shaft kg/m
	4.5	5	16	6	31.4	34.3	7.06	12.6	67.6	12.7	11.8	0.51	1.6
	4.5	7	20	6	56.9	55.9	10.2	17.8	118	16.3	15.5	0.7	2.5
	4.5	8	25	6	105	103	15.2	25.8	210	17.6	18	0.93	3.9
	6.6	10	32	6	180	157	20.5	34	290	20.1	24	1.8	5.6
	9	13	40	6	419	377	37.8	60.5	687	37.2	42.5	3.9	9.9
	11	13	50	6	842	769	60.9	94.5	1340	41.7	54.1	6.7	15.5
	11	13	60	6	1220	1040	73.5	111.7	1600	53.1	68.4	8.8	22.3

Note) M_A indicates the permissible moment value in the axial direction when a single spline nut is used, as shown in the figure above.

Dimension U represents the dimension from the head of the hexagonal-socket-head type bolt to the spline nut end.

For details on the maximum lengths of ball spline shafts by accuracy, please see **A3-109**.