

HSR-M1VV

LM Guide Medium-to-low Vacuum Type Model HSR-M1VV

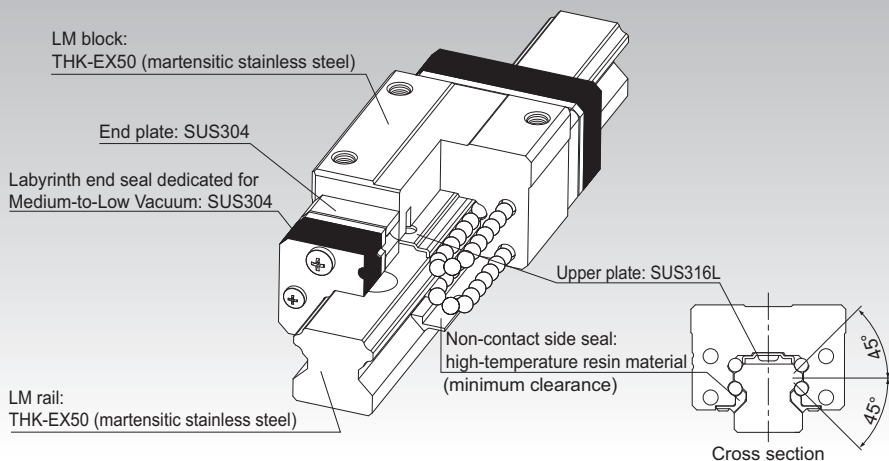

Point of Selection **A1-10**

Point of Design **A1-434**

Options **A1-457**

Model No. **A1-522**

Precautions on Use **A1-530**

Accessories for Lubrication **A24-1**

Mounting Procedure and Maintenance **B1-89**

Equivalent moment factor **A1-43**

Rated Loads in All Directions **A1-58**

Equivalent factor in each direction **A1-60**

Radial Clearance **A1-71**

Accuracy Standards **A1-76**

Shoulder Height of the Mounting Base and the Corner Radius **A1-445**

Permissible Error of the Mounting Surface **A1-450**

Flatness of the Mounting Surface **A1-452**

Dimensions of Each Model with an Option Attached **A1-470**

Structure and Features

[Features]

- Operable in various environments at pressure between atmospheric pressure and vacuum (10^{-3} [Pa]).
- Capable of withstanding baking temperature up to 200°C^*
- Use of a newly developed labyrinth end seal dedicated for Medium-to-Low Vacuum increases grease retention and allows extended use in vacuum.
- Use of grease designed for Medium-to-Low Vacuum achieves a stable rolling resistance.

* If the baking temperature exceeds 100°C , multiply the basic load rating with the temperature coefficient.

Structure of the labyrinth end seal dedicated for Medium-to-Low Vacuum

The labyrinth end seal dedicated for Medium-to-Low Vacuum forms a multi-stage space as shown in the figure on the right to minimize the pressure difference between adjacent stages. This reduces the out-flow velocity of the oil inside the LM block to a minimum. In addition, the seal will not affect the rolling resistance since it does not contact the LM rail.

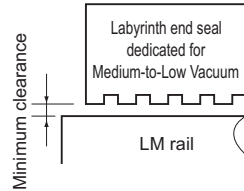

[Achievable vacuum level]

The LM Guide for Medium-to-Low Vacuum demonstrates an excellent achievable vacuum level.

[Test conditions] Temperature: 25°C ($\pm 5^{\circ}\text{C}$)

| | HSR15M1RVV | HSR15R (for reference) |
|----------|---|------------------------|
| Grease | Grease for Medium-to-Low Vacuum | AFB-LF Grease |
| Seal | Labyrinth end seal dedicated for Medium-to-Low Vacuum | None |
| Endplate | Stainless steel | Resin |

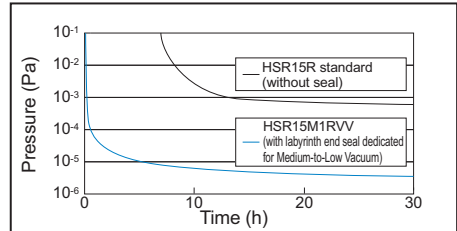

Achievable vacuum level

[Rolling resistance]

The grease used in the LM Guide for Medium-to-Low Vacuum has a smaller rolling resistance than conventional fluorine grease and ensures stable rolling motion.

Specimen: HSR15M1RVV

Temperature: 25°C ($\pm 5^{\circ}\text{C}$)

Pressure: atmospheric pressure

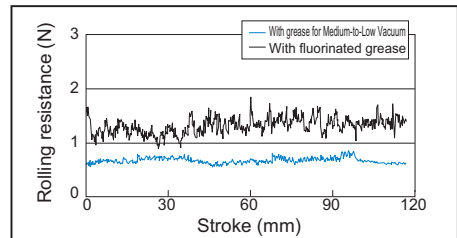

Rolling resistance fluctuation

Types and Features

Model HSR-M1RVV

Specification Table → **A1-380**

With this type, the LM block has a smaller width (W) and tapped holes. Used in places where the space for table width is limited.

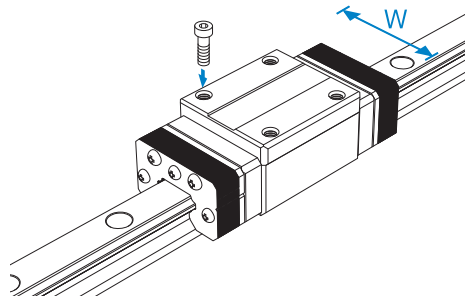

Precautions on Design

If a large moment is applied to a system consisting of one block on one axis, the labyrinth end seal may contact the rail, and it may affect the motion.

If a moment is applied, we recommend using two axes with two blocks per axis.
Contact THK for details.

Model HSR-M1VV

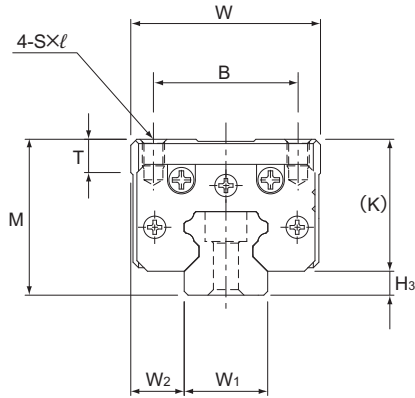

| Model No. | Outer dimensions | | | LM block dimensions | | | | | | |
|-------------|------------------|-------|--------|---------------------|----|--------|----------------|---|------|----------------|
| | Height | Width | Length | | | | | | | |
| | M | W | L | B | C | S × l | L ₁ | T | K | H ₃ |
| HSR15M1R-VV | 28 | 34 | 75 | 26 | 26 | M4 × 5 | 38.8 | 6 | 23.7 | 4.3 |

Model number coding

HSR15M1R 1 VV C1 +400L P - II

Model No.

Radial clearance
symbol^(*1)

Labyrinth seal
symbol^(*2)

No. of LM blocks
used on the same rail

LM rail length
(in mm)

Accuracy
symbol^(*3)

Symbol for
No. of rails used on the
same plane^(*4)

(*1) See **A1-71**. (*2) See **A1-377**. (*3) See **A1-76**. (*4) See **A1-13**.

Note1) The radial clearance, maximum LM rail length and accuracy class are equal to that of model HSR.

Note2) With this model, a single-rail unit constitutes one set (i.e., the required number of sets when 2 rails are used in parallel is 2).

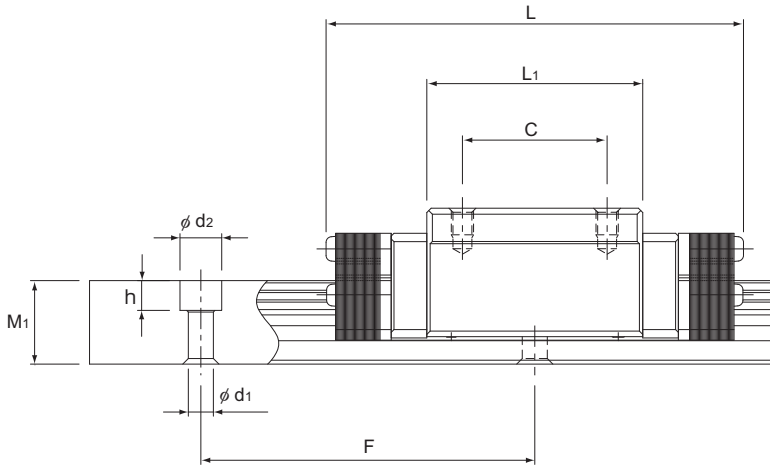

Unit: mm

| LM rail dimensions | | | | | | Basic load rating | | Static permissible moment kN-m* | | | | | Mass | |
|-------------------------|----------------|----------------|----|-------------------------------------|------|-------------------|----------------|---------------------------------|----------------|---------|----------------|----------|---------|------|
| Width | Height | Pitch | | Length* | C | C ₀ | M _A | | M _B | | M _C | LM block | LM rail | |
| W ₁ ±0.05 | W ₂ | M ₁ | F | d ₁ × d ₂ × h | Max | kN | kN | 1 block | Double blocks | 1 block | Double blocks | 1 block | kg | kg/m |
| 15 | 9.5 | 15 | 60 | 4.5 × 7.5 × 5.3 | 1240 | 10.9 | 15.7 | 0.0945 | 0.527 | 0.0945 | 0.527 | 0.0998 | 0.27 | 1.5 |

Note) The maximum length under "Length*" indicates the standard maximum length of an LM rail. (See **A1-382**.)

Static permissible moment*: 1 block: static permissible moment value with 1 LM block

Double blocks: static permissible moment value with 2 blocks closely contacting with each other

If a large moment is applied to a system consisting of one block on one axis, the labyrinth end seal may contact the rail, and it may affect the motion.

If a moment is applied, we recommend using two axes with two blocks per axis.

Contact THK for details.

Standard Length and Maximum Length of the LM Rail

Table1 shows the standard lengths and the maximum lengths of model HSR-M1VV variations. If the maximum length of the desired LM rail exceeds them, jointed rails will be used. Contact THK for details.

For the G dimension when a special length is required, we recommend selecting the corresponding G value from the table. The longer the G dimension is, the less stable the G area may become after installation, thus causing an adverse impact to accuracy.

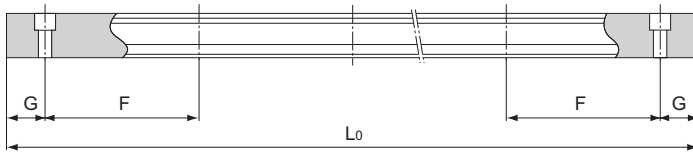

Table1 Standard Length and Maximum Length of the LM Rail for Model HSR-M1VV

Unit: mm

| Model No. | HSR15M1R-VV |
|-----------------------------------|-------------|
| LM rail standard length (L_0) | 160 |
| | 220 |
| | 280 |
| | 340 |
| | 400 |
| | 460 |
| | 520 |
| | 580 |
| | 640 |
| | 700 |
| | 760 |
| | 820 |
| | 940 |
| | 1000 |
| 1060 | |
| 1120 | |
| 1180 | |
| 1240 | |
| Standard pitch F | 60 |
| G | 20 |
| Max length | 1240 |

Note1) The maximum length varies with accuracy grades. Contact THK for details.

Note2) If jointed rails are not allowed and a greater length than the maximum values above is required, contact THK.

